



PERFORMANCE DATA SHEET

Meets or exceeds MEPS (Minimum Efficiency Performance Standards), as described by the US Department of Energy in docket 10CFR431 and Natural Resources Canada's Amendment 14

Catalogue #: MTR-304FDCH

HP	kW	Voltage	Frequency	EFF.	P.F.	Frame	Design	F.L. RPM
3	2,24	208 - 230	60Hz	87,4%	0,978	184TC	B	1770

FLA			Service Factor	N.L. Amps @ 115V	N.L. Amps @ 230V	KVA Code	L.R. Amps @ 15v	L.R. Amps @ 230v
115	208	230		1,15	/		2..66	H
/	13,2	11,30						

Start Cap.	Run Cap.	Main Winding Ω 115V @ 25°C	Main Winding Ω 230V @ 25°C	Auxillary Winding Ω @ 25°C	Safe Cold Start (Secs)
300 μ f/300vac	60 μ f/450vac	/	0,810	1,280	12

Wgt. Lbs	PH	Duty	Insul. Class	Amb.	Elevation	Temp. Rise° C
96	1	Cont.	F	40°C	1000M (3,300 Ft)	76

% Efficiency		Power Factor		Torque		Protection
Full Load:	87,4%	Full Load:	0,98	Full Load Ft/Lbs	8,9	
3/4 Load:	75,0%	3/4 Load:	0,95	Locked Rotor %	175	
1/2 Load:	55,5%	1/2 Load:	0,93	Break Down %	230	

Rotor Inertia Wk2 Lb-Ft2	Max Load Inertia Wk2 Lb-Ft2	Shaft Material	Frame Material	DE Bracket Type	ODE Bracket Type	Enclosure	NEMA Rating	Lead Wire Size
/	/	Steel	Rolled Steel	Aluminium Alloy		TEFC	IP55	/

Ball Bearings		Grease	Mount Type	Orientation	Paint	Sound Pressure @ 3FT	Sound Power
DE	ODE						
6206	6205						

WIRING CONNECTION DIAGRAM : D

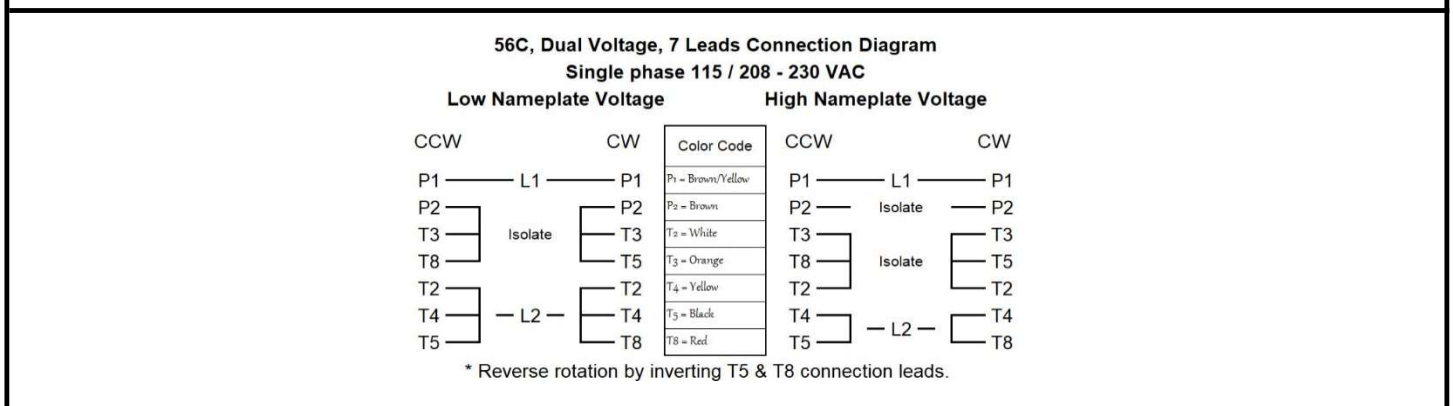



Date: 2023-12-22
 Customer: _____
 Contact: _____
 Submittee: J.C. Lavallée

Catalogue #: **MTR-304FDCH**

Meets or exceeds MEPS (Minimum Efficiency Performance Standards), as described by the US Department of Energy in docket 10CFR431 and Natural Resources Canada's Amendment 14

HP	VAC	RPM	Enclosure	Frame	Frequency	Design	Poles	LR Code Letter	Insulation Class	Temp. Rise °C
3	230	1770	TEFC	184TC	60	B	4	H	F	76

	0%	25%	50%	75%	100%	125%	150%
Load %	0%	25%	50%	75%	100%	125%	150%
Amps	8,02	8,59	9,16	9,94	11,30	14,13	16,95
Torq ft/lbs	0	2,20	4,41	6,65	8,90	11,17	13,47
RPM	0	1792,5	1785	1777,5	1770	1762,5	1755
Eff	0	31,47	57,26	77,36	87,40	89,84	92,68
PF	0,00	90,00	92,71	94,87	97,80	95,84	92,91

	Locked Rotor	Pull-Up	Breakdown	Rated Load	Idle	Duty	S. F.	Ambient	Elevation	dBa @ 1M
Speed (RPM)	0	900	1440	1770	1800	Continuous	1,15	40°C	3,300 ft	70
Current (Amps)	75	63,8	44,6	11,3	8,023	VFD Rating: Meets MG1 parts 31.4.4.2				
Torque (ft-lbs)	15,58	13,24	20,47	8,90	0,0	C.T.	0,81	V.T.	1,28	

